

9/5/2016

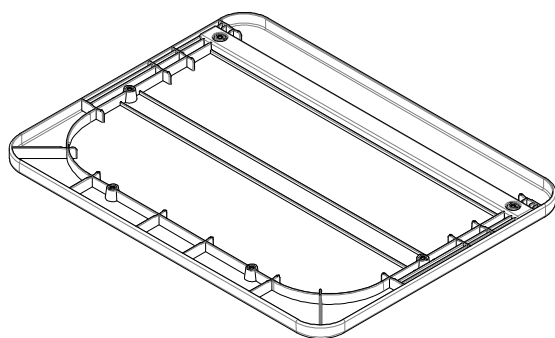

PERSPECTIVAS
ESC. 1 : 10

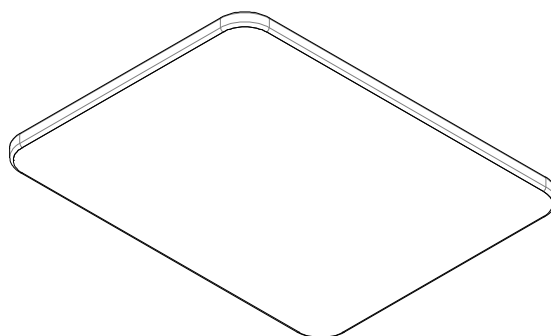

VISTA LATERAL
ESC. 1 : 10

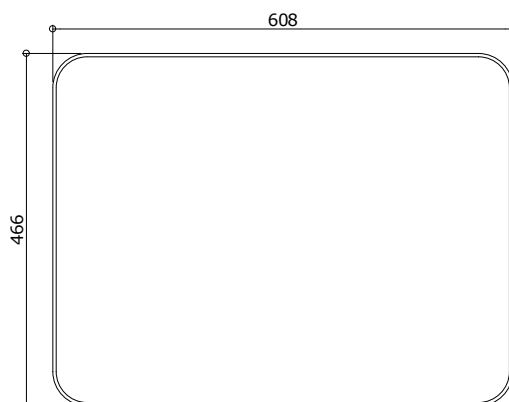

VISTA SUPERIOR
ESC. 1 : 10

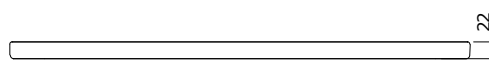

VISTA FRONTAL
ESC. 1 : 10

1 / 3



Atenção

Preserve a escala

Quando for imprimir, use folhas A4 e desabilite a função "Fit to paper"

Respeite o Meio Ambiente.

Imprima somente o necessário

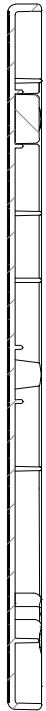

CORTE A-A
ESC. 1 : 5

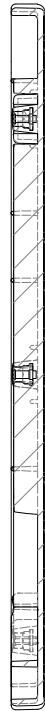

CORTE B-B
ESC. 1 : 5

DETALHE F

DETALHE G

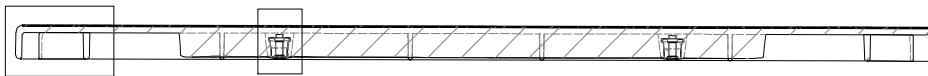

CORTE C-C
ESC. 1 : 5

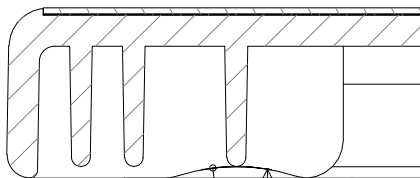

CORTE D-D
ESC. 1 : 1

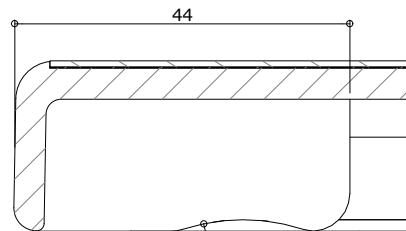

CORTE E-E
ESC. 1 : 1

R26

ACOMODÇÃO PARA ESTRUTURA TUBULAR

R26

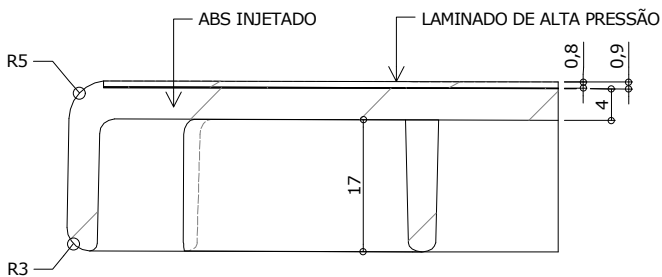

DETALHE F
ESC. 1 : 1

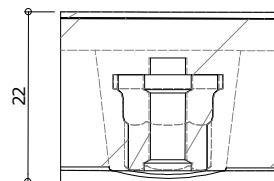

DETALHE G
ESC. 1 : 1

3 / 3



Atenção

Preserve a escala

Quando for imprimir, use folhas A4 e desabilite a função "Fit to paper"

Respeite o Meio Ambiente.

Imprima somente o necessário