

ESPECIFICAÇÕES

PUXADOR INJETADO EM POLIPROPILENO
COPOLÍMERO VIRGEM COM PORCA DE 1/4" CO-INJETADA

TOLERÂNCIAS DIMENSIONAIS

LARGURA E COMPRIMENTO: +/- 0,5 MM
ESPESSURA: +/- 0,1 MM
RAIO: +/- 0,5 MM

CORES

AMARELO / LARANJA / AZUL / VERDE
VERIFICAR ANEXO I - OPÇÕES DE CORES

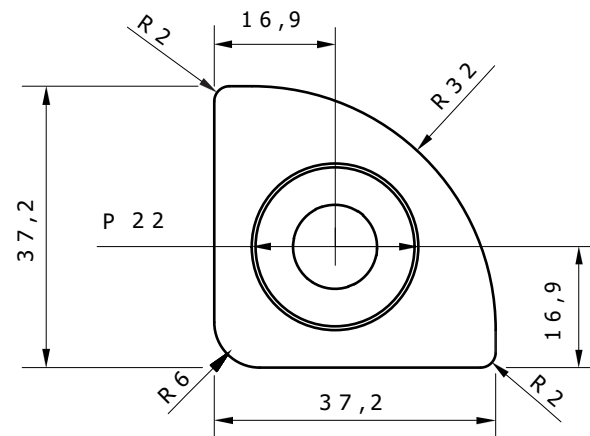

VISTA INFERIOR
ESC. 1:1

